

SCALE: 1/4

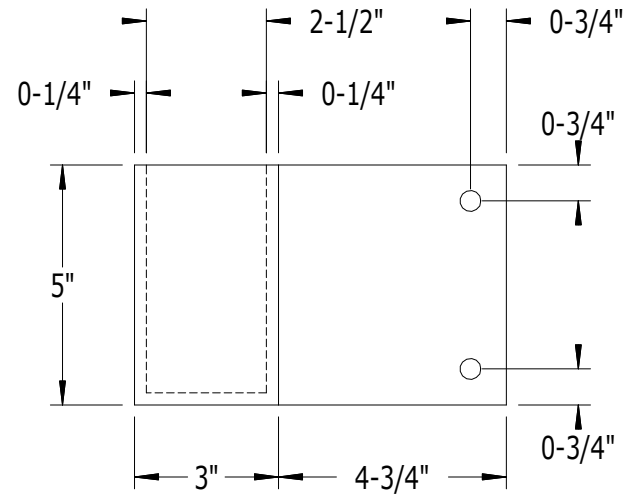

VIEW A

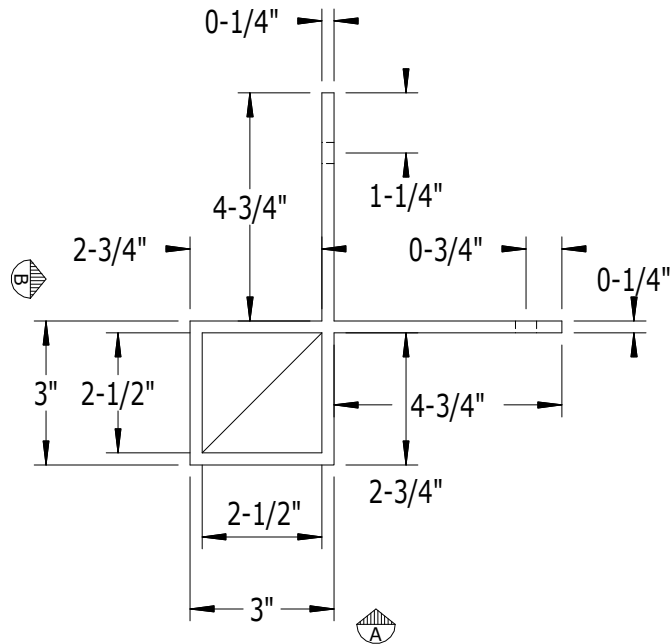
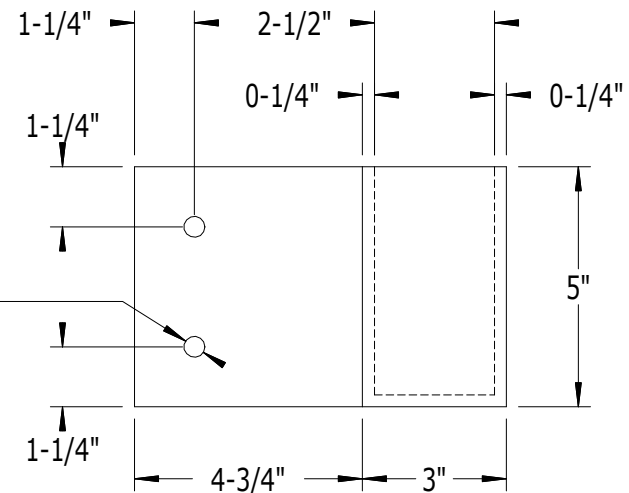

VIEW B

7/16" DIA. ANCHOR HOLES
(3/8" DIA. FASTENERS REQ'D)

PART NO.	DESCRIPTION
976 OSC	OUTSIDE CORNER SIDE MOUNT BASE FOR 2-1/2" SQ. POST

SUPERIOR
ALUMINUM PRODUCTS